

NARKOVET II

SMALL ANIMAL ANESTHESIA MACHINE

USER MANUAL



Art. No. 213130

TELEPHONE +49 7461 96 580 0

www.eickemeyer.com

veterinary technology for life
Eickemeyer®

Contents

1.	Introduction	4
1.1	Overview	4
1.2	Features.....	4
1.3	Product Applications	5
1.4	Environmental Requirements.....	5
1.5	Product Parameters	5
1.6	Product Configuration.....	6
2.	System Safety	7
2.1	Important Symbols	7
2.2	Use Restrictions	7
2.3	Safety Information	7
	2.3.1 Animal and Operator Safety.....	7
	2.3.2 System Protection.....	8
	2.3.3 Environmental Hygiene	8
2.4	System Malfunction.....	8
3.	System Structure	9
4.	System Preparation	13
4.1	Unpacking.....	13
4.2	Installation Steps	14
	4.2.1 Assembling the Anesthesia Machine Trolley.....	14
	4.2.2 Installing the Main Frame.....	16
	4.2.3 Installing the CO ₂ Absorber Canister	17
	4.2.4 Installing the Breathing Bag	17
4.3	System connection.....	18
	4.3.1 Installing the Rebreathing Circuit.....	18
	4.3.2 Installing the Non-rebreathing Circuit	18
4.4	Preparation for Operation.....	18
	4.4.1 Materials and Supplies.....	18
	4.4.2 System Regulating.....	19
	4.4.3 Anesthetic Filling.....	20

5.	Operating Instructions	22
5.1	Check before Use.....	22
5.2	Veterinary Anesthesia.....	22
5.3	Using the O ₂ Flush Button.....	23
5.4	Using Non-rebreathing and Rebreathing Circuits.....	23
5.5	Adjusting the Maximum Pressure Limit in the Breathing Circuit	24
5.6	Post-anesthesia Operation	25
6.	Troubleshooting	25
7.	Maintenance	30
7.1	Safety Precautions.....	30
	7.1.1 Necessary Materials and Items	30
7.2	Equipment Cleaning.....	30
7.3	Equipment Disinfection.....	30
7.4	Upkeeping.....	30
	7.4.1 CO ₂ Absorbent Replacement	31
	7.4.2 Vaporizer Emptying	31
7.5	Weekly Equipment Maintenance	32
7.6	Component Materials.....	32
7.7	Record and Save	32
8.	Other Reference Information	33
8.1	Pressure Measurement	33
8.2	Conversion of Pressure Units.....	33
8.3	Minimum Alveolar Concentration (MAC) Reference for Common Inhalation Anesthetics	33

1. Introduction

1.1 Overview

Before installing and using this product for the first time, be sure to read all the materials attached carefully to help you use this product better.

EICKEMEYER® is committed to continuously improving product functions and service quality. EICKEMEYER® reserves the right to make changes to any product described in this manual and the content of this manual without prior notice.

To get the latest product information, call us or visit our website (www.eickemeyer.com). Please contact EICKEMEYER® if you find any discrepancy between this manual and the actual situation of the product during the use of the equipment or have any questions or suggestions.



The anesthesia machine for small animals should be operated and managed by trained professionals!



This equipment is intended for use in animal clinical and research purposes only and is prohibited for use on humans!

1.2 Features

- Inhalation anesthesia is specially designed for animals such as dogs, cats, monkeys, pigs, birds and amphibians weighing no greater than 100 kg.
- Small footprint and ability to support anesthesia-related small to medium-sized equipment and accommodate anesthesia machine consumables.
- 0.1 ~ 4 L/min, compatible with 0.1 ~ 10 L/min O₂ flowmeter for real-time adjustment and observation with precise control.
- Quick oxygenation function, removing anesthesia gas mixture that resides in the pipe at 10 ~ 15 L/min.
- Adjustable pressure limiting (APL) valve, with a pressure scale and allowing for adjusting the upper limit of circuit pressure. Independent pressure relief and one-button close functions, protecting animals from injuries caused by excessive gas pressure.
- Equipped with a 2100 mL CO₂ absorber canister, with a quick detaching and switching design that facilitates the replacement of calcium lime and a front mounting design that makes it easier to observe.
- Adopt a novel vaporizer that offers improved adaptability to high flowrates, making it well-suited for large animal experiments or surgeries.
- The vaporizer enables adjustable output concentrations of 0 ~ 5% (isoflurane) and 0 ~ 8% (sevoflurane). The output remains unaffected by changes in flowrate, temperature, flow speed, or pressure. The safe locking mechanism prevents accidental anesthetic volatility.
- Oxygen concentrator tray and ventilator tray are optional. The anesthesia machine can accommodate veterinary oxygen concentrators and ventilators, making it convenient for the integrated management of animal respiratory anesthesia equipment.
- The anesthesia machine has a compact and aesthetically appealing structure, along with user-friendly operation.

1.3 Product Applications

This product is designed for most clinical operations on animals such as dogs, cats, monkeys, pigs, birds and amphibians. It can be used in various scenarios such as animal surgeries, imaging, and experiments, meeting the requirements of most veterinary professionals.

1.4 Environmental Requirements

Please prepare the equipment operating environment according to the conditions listed in the table below to ensure the operability and safety of the system.

Environment for the equipment	Detailed Description
Working environment	Temperature: 10°C ~ 35°C
	Humidity: 5% ~ 90% (non-condensing)
	Air pressure: 86 kPa ~ 106 kPa
Storage and transportation environment	Temperature: -10°C ~ 55°C
	Humidity: 5% ~ 90% (non-condensing)
	Air pressure: 86 kPa ~ 106 kPa

1.5 Product Parameters

Item	Specification
Dimensions	L × W × H: ≤ 360 mm × 380 mm × 1400 mm
Weight	≤ 33 kg
Material	Mainly aluminum alloy
Gas source flowrate	0.2 ~ 10 L/min when the required concentration is no greater than 4%, 0.2 ~ 8 L/min
Gas source quality requirements	Medical oxygen
Gas source pressure range	< 0.5 Mpa
Controlled concentration range	Isoflurane: 0 ~ 5% (v/v); Sevoflurane: 0 ~ 8% (v/v)
Concentration range value	Isoflurane: 0 ~ 0.5 ~ 1.0 ~ 1.5 ~ 2.0 ~ 2.5 ~ 3.0 ~ 3.5 ~ 4.0 ~ 5.0 % (v/v)
	Sevoflurane: 0 ~ 0.5 ~ 1.0 ~ 2.0 ~ 3.0 ~ 4.0 ~ 5.0 ~ 6.0 ~ 7.0 ~ 8.0 % (v/v)
Anesthetic perfusion	Approx. 120 mL between the minimum and maximum scales of the visible liquid level
Anesthetic consumption	Approx. 3 × supply gas flowrate (L/min) × set concentration value (% (v/v)) Example: When the concentration of isoflurane is 2% and the gas flowrate is adjusted to 600 mL/min, theoretically a 100 mL bottle of isoflurane can be used for about 28 hours

Item	Specification
Anesthetic loss	22°C, 0 scale, less than 0.5 mL/24 h
Maximum pressure load	50 kPa (vaporizer)
Maximum angle of inclination for use	30°

1.6 Product Configuration





 Note: Due to the differences between different versions of the user manual, this product list is for reference only. Please check the delivered parts against the enclosed packing list upon receipt and contact your EICKEMEYER® service immediately if any discrepancies are identified.

Config.	Name	Qty.	Usage description
Standard	Mobile anesthesia machine - main unit	1 pcs	Used to anesthetize animals
Standard	Anesthesia machine trolley	1 pcs	Supports the main unit of the anesthesia machine
Standard	Reusable non-latex breathing bag -0.5 L	1 pcs	Connects to the anesthesia circuit for gas buffering
Standard	Reusable non-latex breathing bag -1 L	1 pcs	
Standard	Reusable non-latex breathing bag -2 L	1 pcs	
Standard	Anesthesia breathing circuit – middle branch-22mm (M)/15mm (F), 1.5m	1 pcs	Forms a rebreathing circuit (RB)
Standard	Mapleson F type non-rebreathing circuit (Jakson-Rees) – Chinese	1 pcs	Forms a non-rebreathing circuit (NRB)
Standard	Bellows-ID 22.0mm, L1.2m	1 pcs	Connects to the filter canister and discharges exhaust anesthesia gas
Standard	Oxygen tube -ID8.0-9/ 16 union -M16*1.5 union -2M	1 pcs	Connects high-pressure oxygen sources
Standard	Gas filter canister – large	1 pcs	Used to filter exhaust anesthesia gas
Standard	Storage basket	1 pcs	Accommodates anesthesia items
Optional	Oxygen pressure reducing valve - single gauge/without pressure adjustment handle/input 4 MPa, output 0.4 ~ 0.45 MPa	1 pcs	Connects high-pressure oxygen sources
Optional	Miller bulb laryngoscope (5 lenses + handle + carrying case)	1 pcs	Used to assist in endotracheal intubation procedures
Optional	NarkoVet SAV II ventilator tray	1 pcs	For supporting the NarkoVet SAV II Small Animal Ventilator

2. System Safety

 Note: For safety reasons, please read the safety instructions carefully.
If you have any questions or suggestions, please reach out to us for further technical support!

2.1 Important Symbols

Symbol	Description
	Rebreathing/Non-rebreathing
	Gas inlet
	Gas outlet
	Ventilator or Breathing bag port labeling
MIN	Minimum (ALP valve open)

2.2 Use Restrictions

The NarkoVet II small animal anesthesia machine is intended for use in animal experimentation or veterinary medicine only, and all operation and maintenance must be carried out in accordance with the instructions in this manual.

The following improper uses may cause injuries to animals and operators:

- Using gas sources with inappropriate compositions.
- Using gas sources at pressures exceeding the equipment's limit.
- Using incorrect anesthetic.
- Unauthorized modifications to the equipment's structure.

2.3 Safety Information

2.3.1 Animal and Operator Safety

- If conditions permit, please ensure that a spare anesthesia machine is made available for an emergency.
- Please read and familiarize yourself with this user manual before installing and operating the equipment.
- To ensure the stable operation of the system, please read the "**4- System Preparation**" carefully before inspection.
- Please ensure that this system is operated by trained personnel.
- After the warranty period, it is advisable to arrange an annual inspection service to ensure the system's continued stability. Only personnel authorized by EICKEMEYER® are allowed to maintain the product or replace internal components.
- This product should not be used in environments containing open flames and flammable or explosive materials (e.g., ether, acetone, etc.).
- Do not place any objects weighing over 8 kg on the anesthesia machine.
- Ensure that the gas source tube is clear and prevent it from being folded and clogged.

- It is advisable to wear personal protective equipment during the experiment.
- Ensure that the proper connection between the gas source tube and the anesthesia machine before experiments.
- Ensure that the anesthetic gas exhaled by animals is filtered through the exhaust gas treatment device before being vented into the environment.
- It is advisable to monitor animals' vital signs during the anesthesia process to ensure their safety.
- In case of any signs of abnormal functioning, turn off the system and contact EICKEMEYER® for further after-sales support.
- Do not pour any liquid other than the specified anaesthetic into the vaporizer. The vaporizer is designed to be used with compatible anesthetics only. Please carefully observe the usage instructions indicated on the exterior of the vaporizer.
- Ensure that the gas pressure of the gas source does not exceed 0.5 MPa.

2.3.2 System Protection

- Prevent the anesthetic liquid from contact with animal masks and other parts. If a small amount overflows, allow it to evaporate naturally without attempting to wipe it with a cloth.
- Do not place any objects weighing over 8 kg on the anesthesia machine.
- For system maintenance, refer to "**7- Maintenance**".
- Ensure that there is sufficient distance between the anesthesia machine, the wall, and other equipment.
- Ensure the stability of the gas source.

2.3.3 Environmental Hygiene

- Promptly collect and clean any excess anesthetic gas mixture that may escape due to excessive pressure.
- Ensure adequate ventilation when using the anesthesia machine in a confined space.
- Dispose of waste and hazardous substances in accordance with local laws and regulations.

2.4 System Malfunction

In the event of abnormal system operation, please refer to "**6- Troubleshooting**" for detailed descriptions of issues, potential causes, and recommended solutions. If you encounter equipment failure that cannot be resolved, please reach out to your local agent or EICKEMEYER® for assistance with after-sales service.

3. System Structure

- Front view

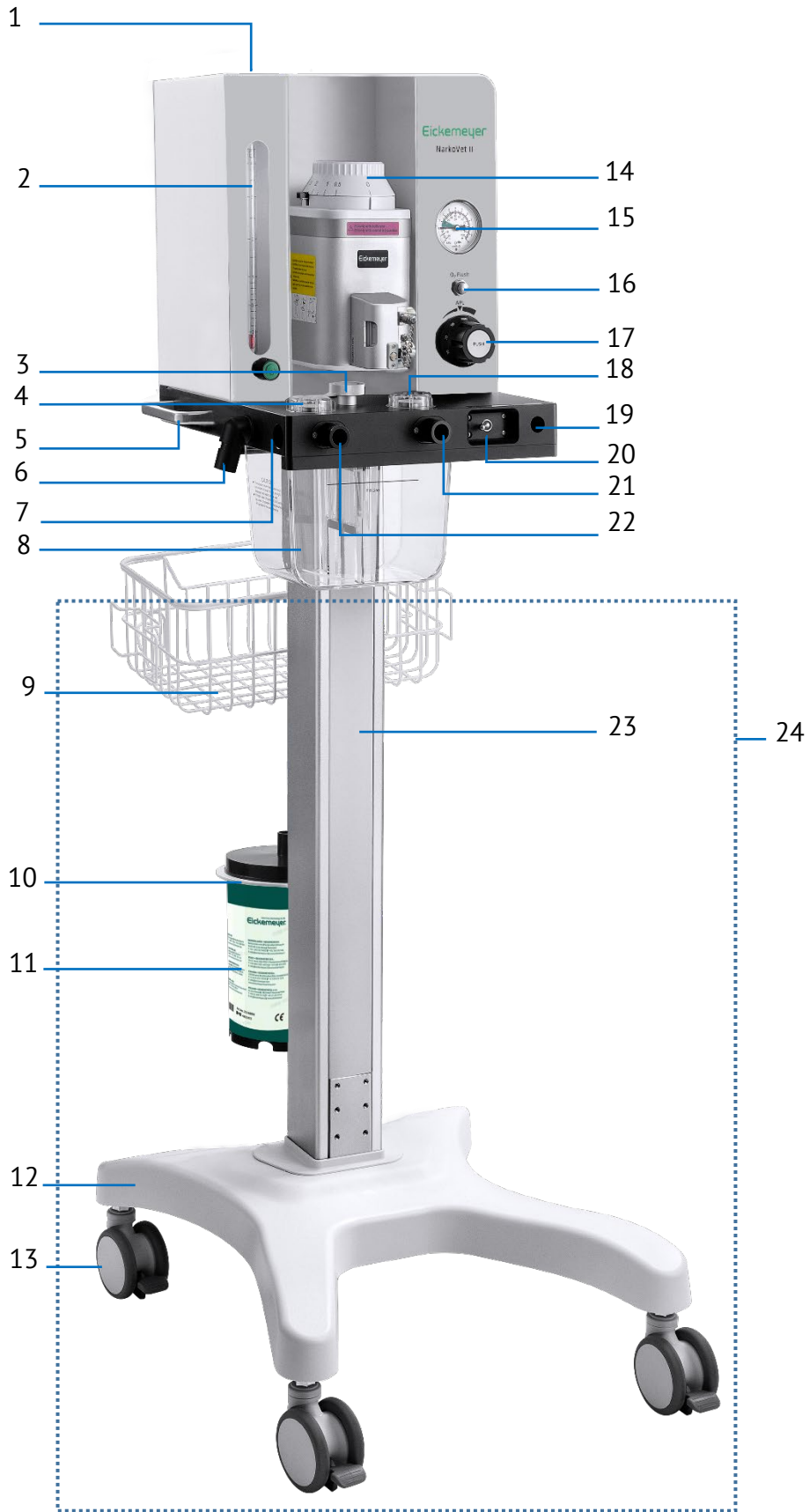

Figure 3-1

SN.	Name	Description
1	Main support	Used to install and support all components except the anesthesia machine trolley.
2	O ₂ flowmeter	Controls the oxygen flowrate into the anesthesia system and achieves accurate regulation by turning the O ₂ flowrate turnknob.
3	CO ₂ absorber canister knob switch	For securely locking the CO ₂ absorber canister. It can be released by turning counterclockwise and locked by turning clockwise.
4	Inhalation/Exhalation valve assembly	A one-way valve assembly composed of a floatable breathing diaphragm and a nickel-plated brass valve is used to control the gas flow in the breathing circuit of the equipment, ensuring the one-way flow of gas when the animal is inhaling and exhaling, thus ensuring that the animal does not inhale the freshly exhaled gas, but only the new anesthetic mixture and the gas that has passed through the CO ₂ absorber canister. The floatable breathing diaphragm will rise and fall with the breathing of the animal, and the transparent dome design allows the user to easily observe the rise and fall of the breathing diaphragm, thus assisting in determining whether the breathing state of the animal is normal.
5	Handle	For moving the anesthesia machine.
6	Breathing bag port	Used to attach a breathing bag. It can provide the necessary gas cushion when the animal is breathing and also can determine whether the breathing status of the animal is normal according to the rise and fall of the breathing bag.
7	Rebreathing circuit port plug	Used to place and block the endotracheal intubation/mask port on the breathing circuit and plays an important role in checking the air tightness of the system, adjusting the pressure limit value of the system and flushing the circuit.
8	CO ₂ absorber canister	Used to place a CO ₂ absorbent (such as calcium lime) that absorbs CO ₂ exhaled by the animal during the breathing cycle, increasing the efficiency of absorption while also reducing resistance to gas flow. The chemical reaction in the absorber canister creates the proper heat and humidity and is added to the anesthetic breathing cycle of the animal.
9	Storage basket	Used to hold anesthesia-related items.
10	Canister holder	Used to hold the gas filter canister.
11	Gas filter canister	Used to adsorb gases such as isoflurane, sevoflurane, and enflurane. For single-use only.
12	H-shaped base	Anesthesia machine trolley, which can be equipped with casters.
13	Casters	3-inch universal casters, each with a locking button.
14	Vaporizer	The vaporizer converts the liquid anesthetic into gas and then adds it to the oxygen by volume percentage (vol.%), which is adjusted by the digital dial on the top of the vaporizer, and the gas that comes out of the outlet is the set concentration of the anesthetic mixture.

SN.	Name	Description
		The vaporizer is the most complex and costly component of the anesthesia machine, requiring special attention for both operation and maintenance. It is recommended to contact EICKEMEYER® after-sales for calibration on a regular basis. The internal design of the vaporizer varies depending on different anesthetics. Please use the anesthetic as stated on the label of the vaporizer. Using the wrong anesthetic may damage the equipment and cause harm to the animals.
15	Airway pressure gauge	Measures and displays the gas mixture pressure in the anesthesia breathing circuit. Note: It is crucial to closely monitor the pressure during veterinary anesthesia. Pressure exceeding 30 cmH ₂ O can lead to internal damage of the pressure gauge itself and potential lung injury or fatality in animals.
16	O ₂ flush button	When pressed, it directly connects the oxygen source to the internal gas circuit of the equipment, allowing oxygen to enter the system circuit directly, and is generally used for flushing residual anesthetic gas from the system.
17	Adjustable pressure limiting (APL) valve	It has independent pressure relief and one-button closing functions. The user can set the maximum pressure limit in the breathing circuit by adjusting the adjustable pressure limiting (APL) valve which can be closed by turning it clockwise and opened by turning it counterclockwise. The valve has scale marking (in cmH ₂ O), with a range from 0 to 70 cmH ₂ O. Pressing the button will increase the pressure scale by approximately 30 cmH ₂ O. Note: When performing non-airtightness checks or using the ventilator, do not completely close the adjustable pressure limiting (APL) valve. Closing it entirely may result in lung injury or fatality for the animal.
19	Non-rebreathing circuit port	A non-rebreathing circuit is recommended for animals generally weighing less than 7 kg. By simply switching the breathing circuit to the NRB position, the exhaust gas exhaled by the animal no longer passes through the CO ₂ absorber canister, but is directly discharged into the gas filter canister or outside.
20	Circuit switch	Allows switching between using the rebreathing circuit (RB) or the non-rebreathing circuit (NRB) with one button.
21/22	Rebreathing circuit port	Used to connect the rebreathing circuit by setting the breathing circuit switch to the RB position. The internal inspiration/expiration valve module works together to prevent animals from inhaling exhaled gas, allowing them to only inhale fresh anesthesia gas mixture and gas that has passed through the CO ₂ absorber canister.
23	Column	Used to assemble and support the main unit, filter canister, storage basket, and oxygen concentrator tray.
24	Anesthesia machine trolley	Used to support the main body of the anesthesia machine for easy movement of the equipment.

- Back view



Figure 3-2

SN.	Name	Description
a	Non-rebreathing circuit tracheal port plug	Used to place and block the endotracheal intubation/mask port on the breathing circuit and plays an important role in checking the air tightness of the system, adjusting the pressure limit value of the system and flushing the circuit.
b	Exhaust gas outlet	When switching to the rebreathing circuit (RB), the exhaust anesthesia gas is vented through this outlet. Use the bellows to connect this outlet to the exhaust gas filter canister, ensuring that the exhaust anesthesia gas is fully filtered before being released into the environment.
c	Gas inlet	Used to connect the oxygen source with pressure not exceeding 0.5 Mpa.

4. System Preparation

 Note: Please prepare the equipment operating environment under the conditions listed in *1.4 Equipment Environmental Requirements* to ensure system operability and safety.

Tip: Please save *all* boxes and packing materials for subsequent transportation.

4.1 Unpacking

The EICKEMEYER® NarkoVet II small animal anesthesia machine is carefully packaged at the factory to ensure safe and smooth delivery to users. Upon receiving the product, please follow the steps below:

- 1) Check against the shipping document to ensure that all packaging boxes have been delivered.
- 2) Inspect the external packaging of the box for any obvious damage. If severe damage is found, immediately notify the carrier and contact EICKEMEYER®. It is advisable to take photos of the damaged packaging as evidence.
- 3) If the packaging is intact and there is no obvious damage, carefully open the packaging box and take out all the equipment components. Keep all packaging boxes and packing materials for future transportation.
- 4) Check the bill of sale or invoice to ensure that all ordered product components are present. If you have any inquiries or need assistance, please contact EICKEMEYER® for service support.

4.2 Installation Steps

4.2.1 Assembling the Anesthesia Machine Trolley

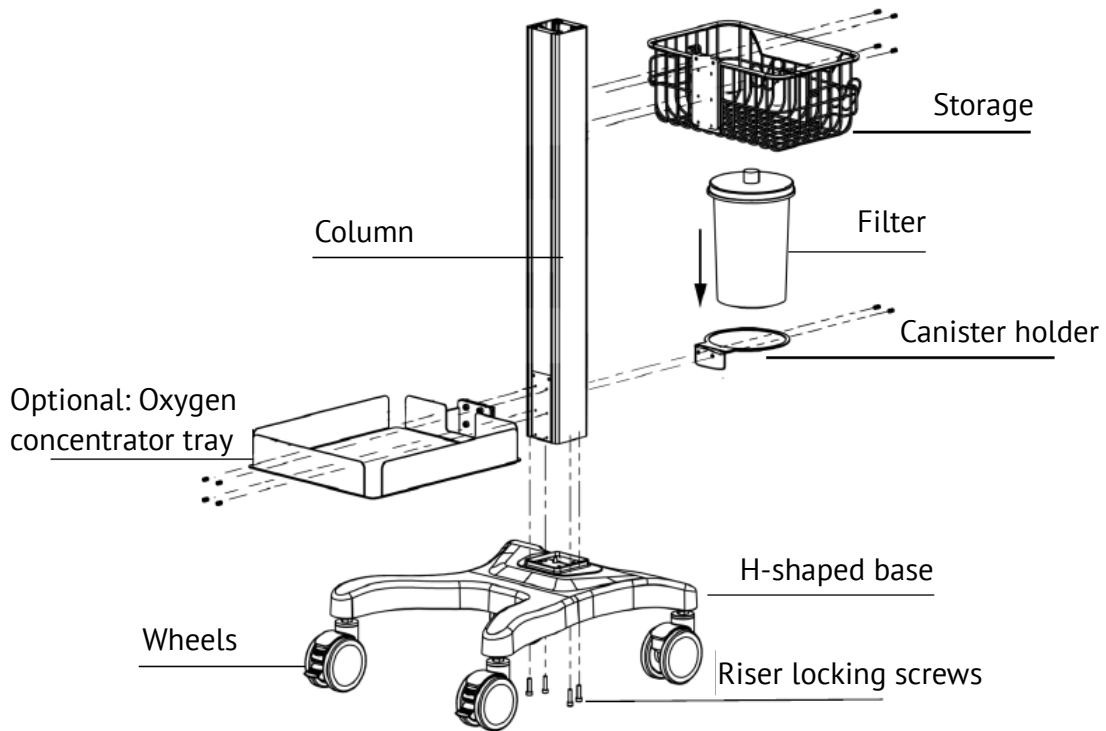
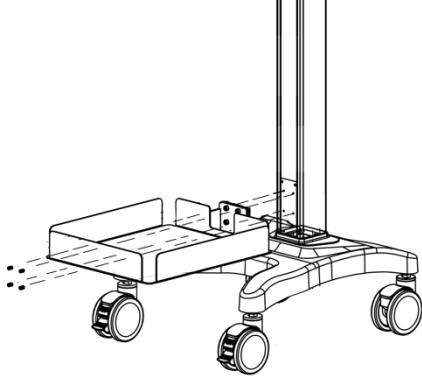
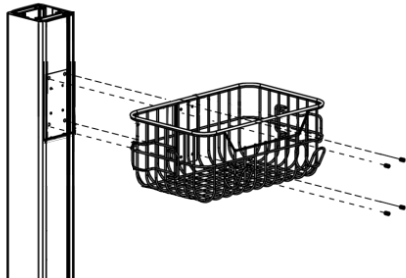
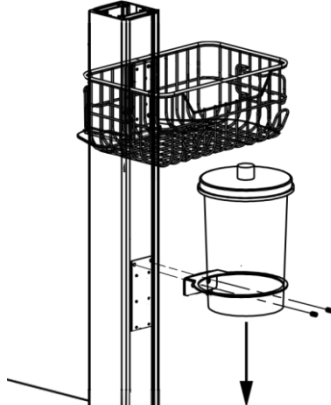

Figure 4-1

Tools required: Allen wrench

SN.	Steps	Schematic diagram
1	<p>Installing the column:</p> <ul style="list-style-type: none"> • Insert the column into the base in the direction as shown in the diagram. • Screw in four Allen screws (M6*55mm) from the bottom of the base to fix the column and the base. 	

SN.	Steps	Schematic diagram
2	<p>Installing the oxygen concentrator tray (optional)</p> <ul style="list-style-type: none"> Loosen four Allen screws (M6*16mm), hang the tray on the screws of the slider, and then lock the screws. If you do not purchase this tray, you do not need to unscrew the above screws to avoid loss. 	
3	<p>Installing the storage basket</p> <ul style="list-style-type: none"> Loosen four Allen screws (M4*10mm), hang the storage basket on the screws of the slider, and then lock the screws. 	
4	<p>Installing the filter canister</p> <ul style="list-style-type: none"> Loosen two Allen screws (M4*10mm), hang the bracket on the screws of the slider and then lock the screws. Put the filter canister into the canister support. 	

4.2.2 Installing the Main Frame

4.2.2.1 General Installation

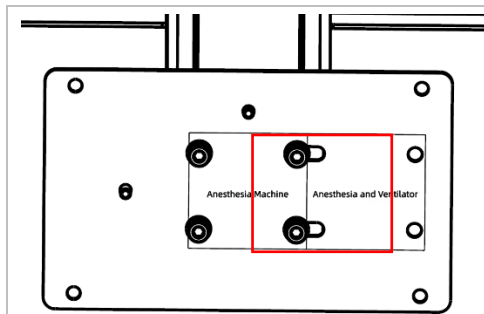

Unscrew four M6 hexagon socket head combination screws, install the trolley connector on the trolley, and lock the four holes in [NarkoVet II] frame with four M6 hexagon socket head screws.

Note: The above 4 screws are only for the fixing of this part and cannot be used for other parts.

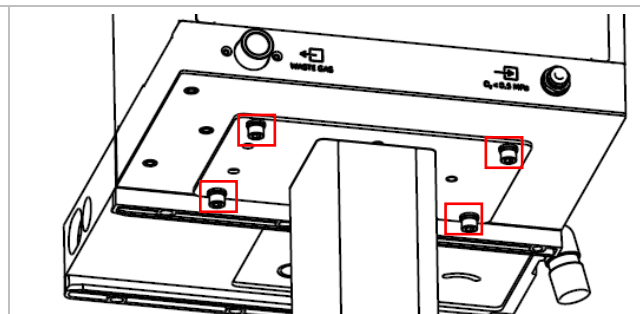

Align the main unit with the pins on the trolley connector, hold the main unit of the anesthesia machine above it steadily, and install the main unit on the trolley connector with four Allen screws (M6*16mm, with metal washer).

Note: Please do not fix with screws of other specifications.

4.2.2.2 Installing NarkoVet SAV II Small Animal Ventilator

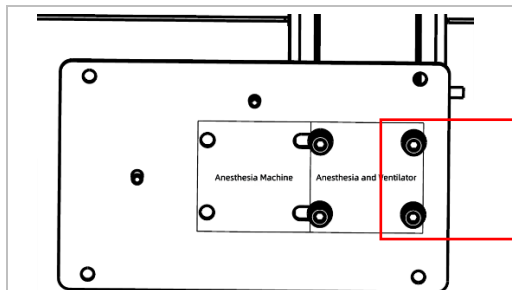

Unscrew four M6 hexagon socket head combination screws on the top of the column, attach the trolley connector on the trolley, and lock the four holes in [NarkoVet II + NarkoVet SAV II] frame with four M6 screws. Note: The above 4 screws are only for the fixing of this part and cannot be otherused for parts.

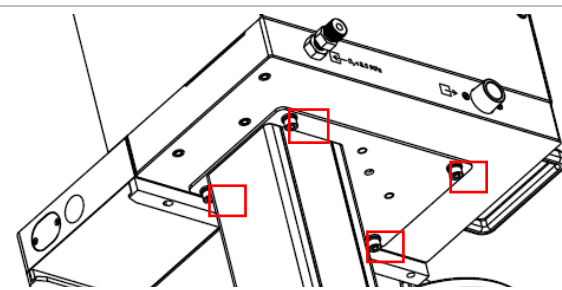

Align the main unit with the pins on the trolley connector, hold the main unit of the anesthesia machine above it steadily, and install the main unit on the trolley connector with four Allen screws (M6*16mm, with metal washer).

Note: Please do not fix with screws of other specifications.

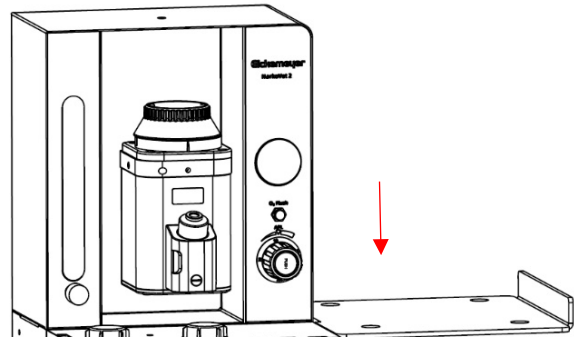
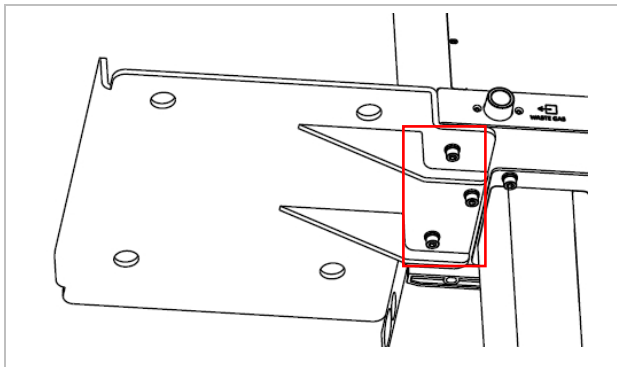

NarkoVet II: Attach the ventilator tray under the base of the main unit with three Allen screws (M6*16mm). NarkoVet SAV II: Attach the ventilator tray on the right side of the main unit with four Phillips screws (M4*12mm).

Place the ventilator at the foot pad hole of the ventilator tray.

4.2.3 Installing the CO₂ Absorber Canister



Fit the absorber canister into the main body of the circuit along the track. Ensure that the absorber canister slide has been pushed to the end.

Secure the absorber canister by turning the locking knob clockwise.

Note: Ensure that the absorber canister slides into the track and pushes it to the end.

4.2.4 Installing the Breathing Bag

Tools required: /

- 1) Cover the breathing bag directly upward at the Breathing bag port and rotate to secure it.



Note: Please choose a suitable breathing bag according to the size of the animal. Too big or too small may cause adverse consequences. If the airbag stops breathing, please check whether the animal is breathing normally and whether the circuit is unobstructed.

Breathing bag recommendations:

Maximum animal weight	Breathing bag size
4.5 kg	1/2 L
4.6 ~ 9 kg	1 L
9.1 ~ 27.2 kg	2 L
37.3 ~ 54.4 kg	3 L
Greater than 54.4kg	5 L

4.3 System connection

4.3.1 Installing the Rebreathing Circuit

Connect the rebreathing circuit lines in the direction as shown below.

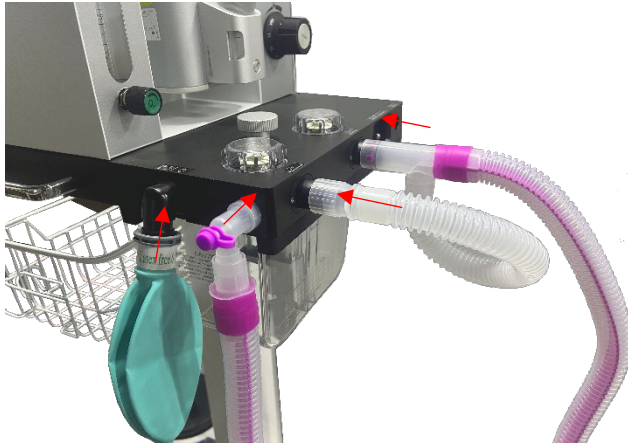

Figure 4-2

4.3.2 Installing the Non-rebreathing Circuit

Connect the non-rebreathing circuit in the direction as shown below.

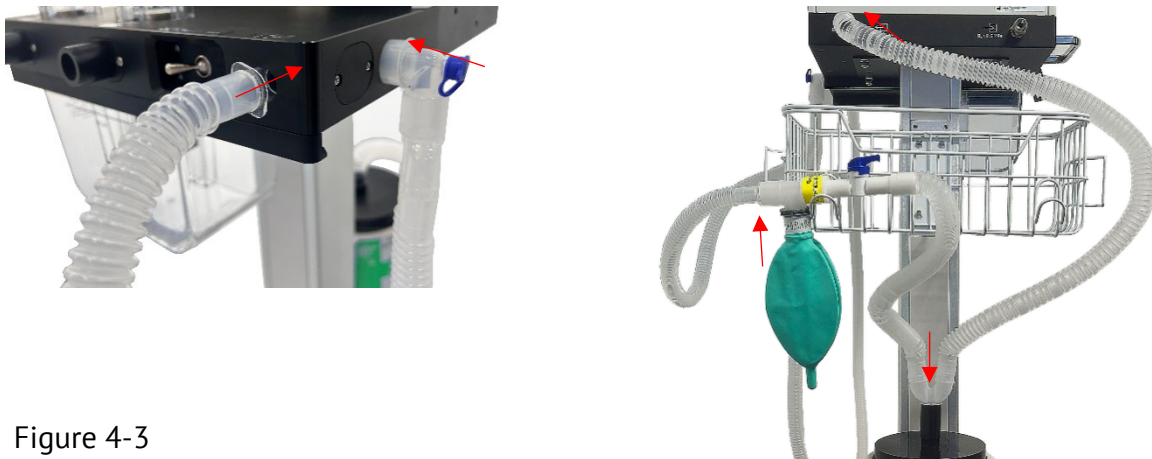

Figure 4-3

4.4 Preparation for Operation

4.4.1 Materials and Supplies

- Oxygen source
- Oxygen source connection tube
- Veterinary anesthesia breathing circuit
- CO₂ absorbent
- Anesthetics (select the appropriate drug according to the type of vaporizer, e.g. isoflurane)
- Wrench tool

Note: When connecting the high-pressure oxygen concentrator, it is necessary to pre-dry the gas. Please seek assistance from your oxygen concentrator supplier.

4.4.2 System Regulating

- Move the anesthesia machine to the use area.
- Fill the CO₂ absorber canister with CO₂ absorbent as follows:
 - a. Loosen the retaining knob and remove the absorber canister.
 - b. Put the CO₂ absorbent into the absorber canister, making sure not to exceed the maximum capacity scale line.
 - c. Install the absorbent canister back onto the main circuit and tighten the retaining knob.



Figure 4-4

- Check the airtightness of the system:
 - a) Ensure that all open ends of the anesthesia machine are closed
 - b) Ensure that the dial of the vaporizer is in the "0" position.



Figure 4-5

- c) Rotate the adjustable pressure limiting (APL) valve clockwise to fully close it.



Figure 4-6

- d) Turn on the gas source from the oxygen cylinder, ensuring that the anesthesia machine's working pressure is within the range of 0.2 ~ 0.4 MPa.
- e) Slowly turn the O₂ flowrate turnknob counterclockwise to introduce the oxygen into the anesthesia machine's tubing for pressurizing, and observe the airway pressure gauge. The pressure can be increased rapidly using the O₂ flush button until it reaches 30 cmH₂O. Then, turn the O₂ flowrate turnknob clockwise to completely close it.

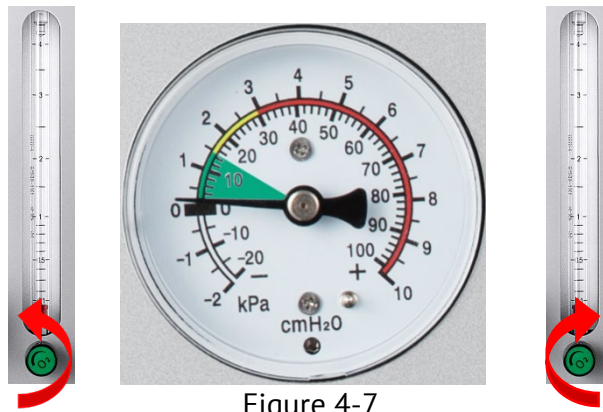

Figure 4-7

- f) Observe the pointer of the airway pressure gauge. If the pointer falls back not greater than one small bar (2 cmH₂O) in 10 seconds, the air tightness is good. If the pointer drops more than 2 cmH₂O within 10 seconds, it indicates a leakage in the system. Please inspect the connections of components.
- g) After the airtightness check, turn the adjustable pressure limiting (APL) valve counterclockwise to the "MIN" scale to ensure that the circuit is open.



Figure 4-8

4.4.3 Anesthetic Filling

Ensure that the correct anesthetic is administered, as the wrong anesthetic can cause serious injury to the animal. If the anesthetic is accidentally spilled on the surface of the equipment, let it evaporate naturally. Wiping with a dry cloth may damage the protective layer on the surface of the component. EICKEMEYER® offers vaporizers with a filling method of Key Fill.



Figure 4-9



Note:

- Ensure that the correct anesthetic is administered, as the wrong anesthetic can cause serious injury to the animal.
- If the anesthetic is accidentally spilled on the surface of the equipment, let it evaporate naturally. Wiping with a dry cloth may damage the protective layer on the surface of the component.
- For the initial fill or if the anesthesia machine has been unused for an extended period, allow the anesthetic to settle for 40 to 60 minutes before use.

4.4.3.1 Key Fill

- 1) Rotate the upper jacking bar counterclockwise to loosen it and take out the current limiting block;



Figure 4-10

- 2) First, ensure that the feedback control lever is tightened, and then insert the adapter into the filer port, rotate the upper jacking bar clockwise to tighten it, and lift the anesthetic bottle up and keep upright to add the agent;



Figure 4-11

- 3) Upon completion of filling, loosen the upper jacking bar and take out the adapter, insert the current limiting block into the filer port and tighten the upper jacking bar.



Figure 4-12

5. Operating Instructions

5.1 Check before Use

EICKEMEYER® recommends performing the following checks before using the NarkoVet II small animal anesthesia machine to ensure stable equipment operation:

- For the first use of the anesthesia machine, allow the anesthetic to settle for 40 to 60 minutes.
- Ensure that a sufficient amount of anesthetics have been added to the vaporizer.
- Ensure that the vaporizer dial indication is set to "0".
- Ensure that the oxygen source is tightly connected to the anesthesia machine.
- Ensure that the gas source pressure does not exceed 0.5 MPa and that there is adequate gas for the entire operation.
- Ensure that the O₂ flowmeter knob can work normally.
- Ensure that the breathing circuit is clear and clean, and check the ventilation and cleanliness of the experimental environment.

5.2 Veterinary Anesthesia

- 1) After inducing anesthesia for the animal, insert an endotracheal intubation or wear a mask.
- 2) Turn the O₂ flowrate turnknob counterclockwise to enable oxygen to enter the tubing system of the anesthesia machine.



Note: As shown “” in the diagram at the top of the flowmeter, taking the upper edge of the red float as the reference.



- 3) Press the scale dial lock key, toggle the vaporizer scale dial, and adjust the anesthesia gas concentration to the appropriate value.
Note: When reducing the concentration, simply toggle the scale dial.



- 4) Connect the breathing circuit port to the endotracheal intubation or anesthesia mask to administer anesthesia gas to the animal.
Tip: The vaporizer dial can be adjusted at any time during the animal's anesthesia to change the concentration of the output anesthetic gas and achieve different levels of anesthesia depth.

5.3 Using the O₂ Flush Button

The O₂ flush button is required if the animal requires an emergency oxygen supply during anesthesia. To use it, follow the following steps:

- 1) Set the vaporizer dial to "0", unplug the breathing circuit port from the animal's mask or endotracheal intubation, and attach it to the port plug of the main unit to close it.
- 2) Press the O₂ flush button and squeeze the breathing bag to expel as much anesthetic gas from the system as possible.
- 3) Then reconnect the breathing circuit port to the mask or endotracheal intubation, adjusting the oxygen flow meter, animals can breathe pure oxygen by inhaling pure oxygen.
Note: Do not press the O₂ flush button when connecting animals.
- 4) Assist the animal's respiration by pressing the breathing bag with both hands.
- 5) To continue anesthesia, you can directly adjust the vaporizer dial to a high concentration and then adjust it back to the maintenance anesthesia concentration after the animal's state is stable.
Note: It is also important to observe the indication of the system pressure gauge during usage to prevent excessively high internal system pressure.

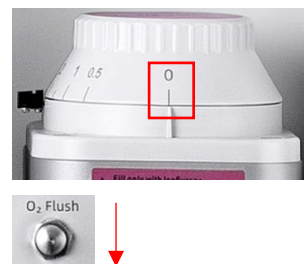

5.4 Using Non-rebreathing and Rebreathing Circuits

It is advisable to use the non-rebreathing circuit to supply anesthesia gas to animals weighing less than 7 kg. By simply switching the breathing circuit switch to the **non-rebreathing position** (NRB), the exhaled gas will bypass the CO₂ absorber canister and directly vent into the gas filter canister or outside. When using the non-rebreathing circuit, **it is forbidden to close the thumb valve, as closing it may cause lung injury or death to the animal**. It is recommended to fully close the adjustable pressure limiting (APL) valve to prevent the exhaust gas from entering the rebreathing circuit.



Figure 5-1

It is advised to supply anesthesia gas to animals exceeding 7 kg. The user only needs to switch the circuit switch to the **rebreathing position (RB)**. When using a rebreathing circuit, **it is essential not to close the adjustable pressure limiting (APL) valve, otherwise, this may cause lung injury or death to the animal.** It is recommended to completely close the switch (thumb valve) on the non-rebreathing circuit (to prevent waste gas from entering the non-rebreathing circuit).



Figure 5-2

5.5 Adjusting the Maximum Pressure Limit in the Breathing Circuit

When the pressure within the breathing circuit exceeds the set value, gas will be vented from the valve to maintain a relatively stable circuit pressure. Follow the steps below to adjust the maximum pressure limit:

- 1) Turn the adjustable pressure limiting (APL) valve counterclockwise to the "MIN" position, ensuring that the airway pressure gauge returns to "0."



Figure 5-3

- 2) Remove the breathing bag and disconnect the circuit at the expiration end of the breathing circuit, then connect it to the Breathing bag port.

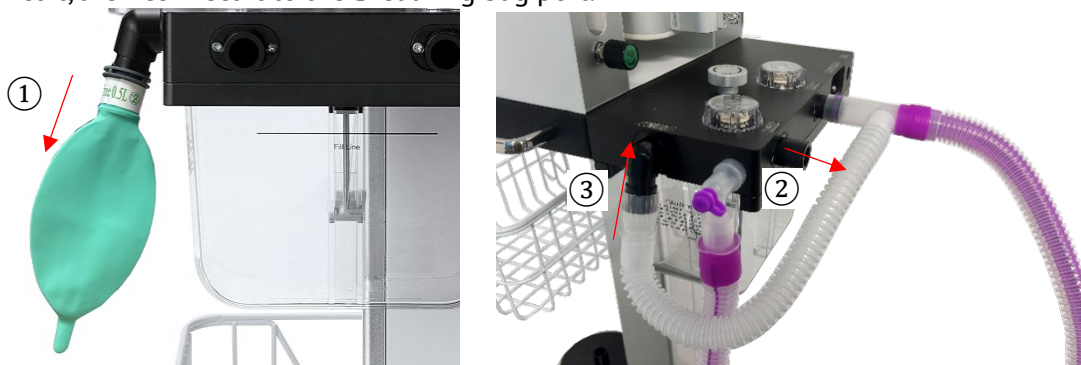

Figure 5-4

- 3) Slowly turn the O₂ flowrate turnknob counterclockwise to allow oxygen to enter the anesthesia machine's circuit system.



Figure 5-5

- 4) Then, slowly turn the adjustable pressure limit valve (APL) clockwise to the desired scale while observing that the airway pressure gauge does not exceed the set value. Generally, it is recommended not to exceed 20 cmH₂O.
- 5) After the system airtightness check and adjusting the maximum pressure in the breathing circuit, turn the O₂ flowrate turnknob clockwise to close it. Then reconnect the breathing circuit to the expiration port and reattach the breathing bag to the Breathing bag port.

5.6 Post-anesthesia Operation

When the anesthesia is completed, please follow the following steps:

- 1) Toggle the vaporizer dial to the "0" scale.
- 2) Unplug the breathing circuit from the anesthesia mask or endotracheal intubation, and connect the breathing port to the port plug of the main unit to close it.
- 3) Press the O₂ flush button and squeeze the breathing bag to promptly eliminate the anesthetic gas and CO₂ from the system tubing.
- 4) Turn off the oxygen source.
- 5) Adjust the O₂ flowrate turnknob until the flow reading indicates "0".
- 6) Record and check the duration of absorbent usage in the CO₂ absorber canister.

Note:

- a) Typically, the CO₂ absorbent should be replaced after 12 hours of cumulative usage, even if it has not been used for a full 12 hours within one month. During replacement, prevent dust spillage and fill the absorber canister up to the Fill Line.
- b) Failure to replace it in a timely manner may lead to high CO₂ concentration in the circuit, leading to respiratory acidosis in animals due to excessive CO₂ inhalation.
- c) For replacement procedures, please refer to "**4-System Preparation**" (The color of the absorbent is provided for reference only, as relying solely on color judgment may result in delayed replacement and ultimately cause respiratory acidosis in animals.)
- 7) If the anesthesia machine is not used for an extended period, refer to "**7-Maintenance**" to empty the anesthetic from the vaporizer.
- 8) Thoroughly the anesthesia machine, refer to "**7-Maintenance**".

6. Troubleshooting

Hazardous substances may be utilized during the troubleshooting process. Please dispose of contaminated waste according to local laws and regulations. Remember to wear basic personal protective equipment (e.g., gloves, masks, goggles, etc.) throughout this process.

Unless otherwise stated, connect the anesthesia machine to the gas source when troubleshooting. However, ensure that both the gas source and vaporizer are turned off before proceeding with any operations. Follow the provided troubleshooting guide for subsequent steps.

It is advisable to maintain a record of the troubleshooting process after addressing the fault. This record should include details such as time, location, fault description, troubleshooting steps, etc., for future reference.

Symptom	Possible Causes	Solution
There is no or little output of anesthetic gas mixture	Abnormal airtightness of the anesthesia machine.	Connect the pipes tightly and check the air tightness. See 4.4.2 System Regulating for details. Replace the parts of air leak.
	The anaesthetic in the vaporizer has been used up.	Fill the anesthetic, keep the agent level between the two marks, and tighten the sealing cap. Note: Adding anesthetics during the surgical process is prohibited.
	The vaporizer is off.	Press and hold the dial lock button and turn the vaporizer dial to adjust it to the appropriate output concentration value.
	There is gas leakage at the filling port of the vaporizer.	Ensure that the sealing cap of the filling port is fully tightened.
	Internal failure of the vaporizer.	Please contact EICKEMEYER® for after-sales service support.
The adjustable pressure limiting (APL) valve is difficult to rotate	The adjustable pressure limiting (APL) valve needs to be cleaned.	Please contact EICKEMEYER® for after-sales service support.
The pointer of the system airway pressure gauge is stuck	Mechanical damage to the airway pressure gauge.	Replace with a new airway pressure gauge, and contact EICKEMEYER® for after-sales support.
The indicator of the system airway pressure gauge is negative	The gas flowrate is too low.	Increase the gas flowrate.
	Airway pressure gauge is not set to zero.	Zero setting.
	Mechanical damage to the airway pressure gauge.	Replace with a new airway pressure gauge, and contact EICKEMEYER® for after-sales support.
The animal is anesthetized too lightly	The vaporizer is off.	Press and hold the scale dial lock button and turn the dial to the appropriate concentration range.

Symptom	Possible Causes	Solution
	Abnormal airtightness of the anesthesia machine.	Connect the pipes tightly and check the air tightness. See 4.4.2 System Regulating for details. Replace the parts of air leak.
	The anaesthetic in the vaporizer has been used up.	Add an appropriate amount of anaesthetic to the vaporizer. Note: Adding anesthetics during the surgical process is prohibited.
	The anesthetic gas concentration is too low.	Adjust the vaporizer scale dial to increase the anesthetic gas concentration, sedative and analgesic drugs may be used before surgery.
	Endotracheal intubation kit/ anesthesia mask and animals don't match.	Replace the Endotracheal Intubation Kit/ Anesthesia Mask.
	Endotracheal Intubation Kit to deep (single lung).	Standardized experimental operation.
	Only occurs in individual animals, individual factors, diseases, etc. should be considered.	Increase the dose of anesthetic and implement a combined anesthetic program.
	There is a gas leak in the veterinary anesthesia breathing circuit.	Check the system's breathing circuit for leaks, ruptures, or holes to ensure a good seal between the anesthesia mask or endotracheal intubation and the animal.
	Excessive accumulation of CO ₂ in the breathing circuit.	1) Check the length of time the calcium lime has been used and replace it with a new one. 2) Check the airtightness of the anesthesia machine.
	There is gas leakage at the filling port of the vaporizer.	Ensure that the sealing cap of the filling port is fully tightened.
The animal is anesthetized too deeply	The anesthetic gas concentration is too high.	Adjust the vaporizer scale dial to decrease the anesthetic gas concentration.
	Abnormal airtightness of the anesthesia machine.	Connect the pipes tightly and check the air tightness. See 4.4.2 System Regulating for details. Replace the parts of air leak.
	Vaporizer failure, the output concentration is abnormal.	Please contact EICKEMEYER® for after-sales service support.
	Flowmeter fault.	Please contact EICKEMEYER® for after-sales service support.

Symptom	Possible Causes	Solution
When the anesthetic machine is not used, the liquid level drops after a period of time	Leakage from the drug discharge port.	1) Clean the sealing cap and tighten it. 2) Tighten the screw of drug discharge port.
	Leakage from the adjustable window.	Please contact EICKEMEYER® for after-sales service support.
	The volume-percent dial clockwise is not rotated to "0".	Turning the volume-percent dial clockwise to "0" after use.
	Abnormal airtightness of the anesthesia machine.	Connect the pipes tightly and check the air tightness. See 4.4.2 System Regulating for details. Replace the parts of air leak.
The breathing bag is overinflated	The adjustable pressure limiting (APL) valve is closed.	Open adjustable pressure limiting (APL) valve.
	The adjustable pressure limiting (APL) valve outlet is clogged.	Check and clean the outlet of the adjustable pressure limiting (APL) valve.
	Wrong airbag selection.	Replace with the correct breathing bag, refer to 4.2.4 Installing the Breathing Bag .
The breathing bag does not inflate during gas flow.	The breathing bag is damaged.	Replace the breathing bag with a new one.
	Abnormal airtightness of the anesthesia machine.	Connect the pipes tightly and check the air tightness. See 4.4.2 System Regulating for details. Replace the parts of air leak.
No gas flow	The gas source is closed.	Open the gas source.
	The gas storage cylinder is empty.	Replace with a new gas storage cylinder.
	The gas source pipe is not connected properly..	1) Ensure that the gas source is properly connected to the anesthesia machine. 2) Ensure that a safe and secure connection between the gas source and the anesthesia machine.
	Abnormal airtightness of the anesthesia machine.	Connect the pipes tightly and check the air tightness. See 4.4.2 System Regulating for details. Replace the parts of air leak.
	O ₂ flowmeter off.	Turn the O ₂ flowmeter turnknob counterclockwise until the desired flow value is obtained.
	Gas source failure.	Check and replace the gas source.

Symptom	Possible Causes	Solution
Insufficient gas flow	The gas source flowrate setting is too low.	Adjust the flowmeter turnknob to increase gas flow.
	The air source pressure is too low.	Replace the oxygen tank.
	There is gas leakage at the filling port of the vaporizer.	1) Ensure that the filling seal cap is fully locked. 2) Check the filling port for animal hair and other residues.
	Abnormal airtightness of the anesthesia machine.	Connect the pipes tightly and check the air tightness. See 4.4.2 System Regulating for details. Replace the parts of air leak.
	There is gas leakage in the CO ₂ absorber canister.	1) Turn off the anesthesia machine. 2) Remove the CO ₂ absorber canister. 3) Clean absorbent or foreign material from the slide, screw holes in the top of the absorber canister, and the gasket. 4) Reinstall the absorber canister.
The O ₂ flush button is stuck	Internal valve failure.	Please contact EICKEMEYER® for after-sales service support.
The float in the O ₂ flowmeter is stuck	Debris in the flowmeter circuit.	Please contact EICKEMEYER® for after-sales service support.
The O ₂ flowmeter turnknob is difficult to turn	Debris trapped or damage inside the turnknob.	Please contact EICKEMEYER® for after-sales service support.
O ₂ flowmeter failure	Internal failure.	Please contact EICKEMEYER® for after-sales service support.
There is noticeable gas leakage noise near the oxygen pipe	Loose tubing connection.	Ensure that the tubing connection is secured firmly.
	Misaligned tubing connection.	Replace with suitable tubing, and check the air tightness. See 4.4.2 System Regulating for details.

7. Maintenance

7.1 Safety Precautions

During maintenance, hazardous substances may be used. Please take basic personal protective measures and follow local laws, regulations, and rules for the disposal of contaminated waste. Unless otherwise specified, during maintenance, the anesthesia machine should be connected to the gas source according to this manual, but make sure that the gas source and vaporizer are off.

7.1.1 Necessary Materials and Items

- Surface cleaning solution (sterilizing cleaning solution, such as 3% hydrogen peroxide or 75% alcohol, etc.).
- Clean water and a clean cleaning cloth.
- Personal protective equipment (gloves, mask, goggles, etc.).

7.2 Equipment Cleaning

- 1) It is recommended to wipe the surface of the anesthesia machine with a clean cloth and an appropriate amount of neutral cleaning solution once a week.
- 2) Clean hair, dust, and other debris from the vaporizer, especially around the dial and the filling port of the anesthesia machine.
- 3) If there are impurities in the rebreathing circuit and non-rebreathing circuit, they can be soaked in soapy water, cleaned, and air-dried. Regular cleaning using this method is also recommended.
- 4) The anesthesia machine trolley can be cleaned using common cleaning agents (e.g., diluted bleach, ammonia, or alcohol solution) and mild non-abrasive solutions. Prevent any liquids from entering the interior of the anesthesia machine trolley.



Avoid contact with some harmful materials or substances during cleaning. It is recommended to wear personal protective equipment (gloves, masks, eye shields, etc.) when cleaning the equipment.

7.3 Equipment Disinfection

- 1) Disinfection with alcohol: The surfaces of instruments (except for O₂ flowmeter, vaporizer, and CO₂ absorber canister) can be disinfected by using a clean cleaning cloth dipped in 75% alcohol.
- 2) UV disinfection: UV disinfection should not be performed too close to the light source.

7.4 Upkeeping

- 1) Check that the CO₂ absorbent has not expired. Note the duration of use of the CO₂ absorbent. The CO₂ absorbent typically needs replacement after 12 hours of continuous use. If not used for the entire 12 hours within a month, refer to "**7.4.1 CO₂ Absorbent Replacement**" for guidance.
- 2) Replace the gas filter canister if it exceeds 1kg.

- 3) Perform routine checks for the airtightness of the entire anesthesia machine system, refer to "**4.4.2 System Regulating**".
- 4) Perform routine checks before use, refer to "**5.1 Check before Use**".
- 5) Check the cleanliness and amount of the oxygen source.
- 6) Empty the vaporizer, refer to "**7.4.2 Vaporizer Emptying**".

7.4.1 CO₂ Absorbent Replacement

- 1) Remove the CO₂ absorber canister from the anesthesia main support and clean out the expired absorbent.



Do not knock the absorber canister heavily, as it may damage the sealing surface!

- 2) Clean the absorber canister with warm water and thoroughly dry it.
- 3) Wipe the sealing gasket of the absorber canister under the bracket with a clean, damp cloth to ensure that there is no absorbent residue on the surface.
- 4) Refill the absorber canister with a new absorbent, making sure not to exceed the Fill Line scale.
- 5) Install the absorber canister back into the bracket and tighten the retaining knob.

7.4.2 Vaporizer Emptying

If the anesthesia machine is not in use for a long time, follow the steps below to empty the residual anesthetic in the vaporizer:



- Please operate the device in a well-ventilated place.
- Please wear personal protective equipment (gloves, masks, eye shields, etc.) when operating the equipment, and dispose of potentially hazardous waste in accordance with local laws and regulations.
- Do not mix anaesthetics with other liquids.



Do not wipe the anesthetic spilled on the surface of the equipment. Otherwise, it may damage the surface. It is recommended to let it evaporate naturally and keep it in a well-ventilated place.

- 1) Make sure the oxygen or air supply is OFF and the vaporizer is set to zero volume-percent.



Figure 7-1

- 2) Make sure the anesthesia system is in a well-ventilated area.
- 3) Unscrew the upper jacking bar counterclockwise to remove the current limiting block and insert the adapter into the outlet.



Figure 7-2

- 4) Rotate the lower jacking bar clockwise to tighten it, and use a screwdriver to unscrew the feedback control lever, so that the anesthetic agent can flow naturally out of the vaporizer.



Figure 7-3

- 5) When no anesthetic agent flows out naturally, tighten the feedback control lever and take out the adapter. Insert the current limiting block into the filler port and turn the upper jacking bar clockwise to tighten it. Dispose of waste anesthetic agents according to regulations.

7.5 Weekly Equipment Maintenance

EICKEMEYER® recommends complete maintenance of the anesthesia machine once a week. The steps are as follows:

- 1) Wipe the surface of the anesthesia machine with a clean cleaning cloth. An appropriate amount of neutral cleaning solution is allowed.
- 2) Clean hair, dust, and other debris from the vaporizer, especially around the dial and the filling port of the anesthesia machine.
- 3) Check if the gas filter canister exceeds 1 kg; replace if it exceeds 1 kg.
- 4) Perform routine checks before use, refer to "**5 - Operating Instructions**."

7.6 Component Materials

If some parts or materials need to be replaced during maintenance, please contact EICKEMEYER® after-sales service for support.

7.7 Record and Save

It is recommended to keep a record of the process after maintenance, including time, place and maintenance procedure for future reference.

8. Other Reference Information

8.1 Pressure Measurement

1 atm = 1033 cmH₂O = 760 mmHg = 760 Torr = 1013 mb = 14.7 psi

1 psi = 70.3 cmH₂O = 51.7 mmHg = 68.9 mb = 6.9 kPa

1 mmHg = 1.36 cmH₂O = 1.33 mb

1 cmH₂O = 0.736 mmHg = 0.981 mb

8.2 Conversion of Pressure Units

Unit	psi	inchH ₂ O	kPa	millibar	cmH ₂ O	mmHg
psi		27.680	6.8947	68.947	70.308	51.715
inchH ₂ O	3.6127×10^{-2}		0.2491	2.491	2.5400	1.8683
kPa	0.14504	4.0147		10.000	10.1973	7.5006
millibar	0.01450	0.40147	0.100		1.01973	0.75006
cmH ₂ O	1.4223×10^{-2}	0.3937	0.09806	0.9806		0.7355
mmHg	1.9337×10^{-2}	0.53525	0.13332	1.3332	1.3595	

8.3 Minimum Alveolar Concentration (MAC) Reference for Common Inhalation Anesthetics

Animal	Halothane	Isoflurane	Sevoflurane
Cat	1.19	1.63	2.58
Dog	0.87	1.3	2.34

Note: MAC is defined as the concentration of anaesthetic within alveolar gas at normal atmospheric pressure, which results in the disappearance of pain sensitivity in 50% of the animals. The value of MAC is not exactly equal to the set value required for the vaporizer during veterinary anesthesia.

GERMANY

EICKEMEYER KG
Eltastraße 8
78532 Tuttlingen
T +49 7461 96 580 0
F +49 7461 96 580 90
info@eickemeyer.de
www.eickemeyer.de

SWITZERLAND

EICKEMEYER AG
Sandgrube 29
9050 Appenzell
T +41 71 788 23 13
F +41 71 788 23 14
info@eickemeyer.ch
www.eickemeyer.ch

POLAND

EICKEMEYER Sp. z o.o.
Al. Jana Pawła II 27
00-867 Warszawa
T +48 22 185 55 76
F +48 22 185 59 40
info@eickemeyer.pl
www.eickemeyer.pl

ITALY

EICKEMEYER S.R.L.
Via G. Verdi 8
65015 Montesilvano (PE)
T +39 085 935 4078
F +39 085 935 9471
info@eickemeyer.it
www.eickemeyer.it

DENMARK

EICKEMEYER ApS
Solbakken 26, Hammelev
6500 Vojens
T +45 7020 5019
info@eickemeyer.dk
www.eickemeyer.dk

NETHERLANDS

EICKEMEYER B.V.
Doejenburg 203
4021 HR Maurik
T +31 345 58 9400
info@eickemeyer.nl
www.eickemeyer.nl

UNITED KINGDOM

EICKEMEYER Ltd.
3 Windmill Business Village
Brooklands Close
Sunbury-on-Thames
Surrey, TW16 7DY
T +44 20 8891 2007
info@eickemeyer.co.uk
www.eickemeyer.co.uk

CANADA

EICKEMEYER Inc.
617 Douro Street
Suite 205
Stratford, Ont. Canada
N5A 0B5
T +1 519 273 5558
info@eickemeyervet.ca
www.eickemeyercanada.ca